

AN EVALUATION OF THE SCREENING MEASUREMENT AS AN INDICATOR OF AVERAGE ANNUAL INDOOR RADON EXPOSURE

Michael W. LaFontaine
LaFontaine Consulting Services
Kitchener, ON - CANADA

ABSTRACT

A study was conducted during the period summer 1994 - summer 1995, to evaluate the radon screening measurement as an indicator of average annual indoor radon exposure. Data for the study was obtained from 24 single family detached homes from across the province of Ontario, Canada. Short-term (four day) radon screening measurements were made in the basement and main living areas of each household, during each season: summer, fall, winter and spring. In addition to the screening measurements, a long-term (annual) radon measurement was made in the main living area of each home. Short-term and long-term measurements were made with E-PERM[®] electret ion chambers.

Using the annual measurement as the reference for each home, results of the study indicated that a screening measurement made in any season had a 50-50 chance of under or over-estimating the average annual indoor radon exposure. No correlation between the short-term screening measurement and long-term annual radon measurement was found.

Results of the annual radon measurements are summarized as follows:

- 16/24 or 66.7% of the measurements exceeded the U.S. EPA action level of 148 Bq/m³ (4 pCi/L)
- 2/24 or 8.3% of the measurements exceeded the "recommended" Canadian guideline of 800 Bq/m³ (22 pCi/L).

INTRODUCTION

Radon

Naturally occurring uranium is present to some degree in most rocks and soils; in North America the average concentration is one part per million (Lafavore 1987). Radon, an inert, radioactive gas, is part of the radioactive decay chain of uranium. It has no odour, colour or taste. Radon accounts for more than 50 percent of the background radiation that Canadians are exposed to (Townsend 1989), and represents the most common source of background radiation in the world (Thomas 1989).

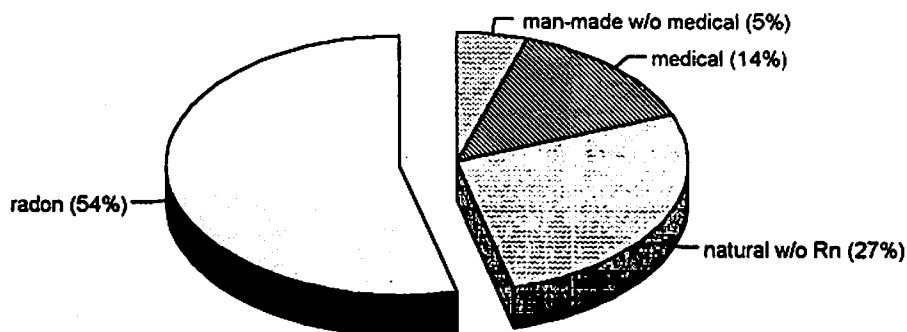

Fig. 1 - Background Radiation Sources

The carcinogenic potential of radon is realized when radon and its decay products are breathed in (Krewski et al 1989). As radon decays, it produces a number of electrically charged decay products, two of these, polonium 218 and polonium 214 are responsible for about 94% of the alpha radiation associated with radon. When inhaled, the radon decay products attach themselves to the lung tissue and can produce cell damage when they themselves decay. Health risk varies with exposure levels.

Most radon entering the home will do so at points of the house in direct contact with the underlying soil; entry points include:

- cracks in the floor slab or foundation wall
- penetrations in the floor slab/walls (sewer, natural gas, water, electrical)
- exposed soil (root cellars, crawl spaces)
- sumps & drains
- slab to wall joints
- hollow support posts
- hollow block walls.

Since the air pressure inside a house is usually lower than that outside the house, even a crack smaller than a pin head in width, can produce soil gas flow that brings radon into the structure (Lafavore 1987). Radon is readily soluble in water, so a wet basement may also be a radioactive one (Cothorn et al 1987). *Note: Even if radon is not present in the water, the water itself is an indicator of porosity or cracks in the building's foundation.* Other sources of radon in buildings include the water supply (if the water comes from wells) or the natural gas supply (rare).

The amount of radon entering a home depends on a number of factors:

- the nature of the soil beneath the house, damp clay can insulate the house from radon entry, whereas, dry cracked clay, sand or glacial till can allow radon to move rapidly from the soil into the foundation
- the condition of the building and number of cracks or openings in the foundation
- weather — wind, temperature, barometric pressure (drops in pressure result in more radon being released from the ground); season — radon levels are generally higher in cold months (building is closed, also, the presence of frost, snow and ice can block radon's release into the air from the surface of the outdoor soil); and lifestyles — the frequency of operation of fireplaces, dryers, exhaust fans, etc., that increase depressurization of the indoor air.

Measurement

Currently, the only way to determine the amount of radon present in a house is to measure it directly. In Canada and the United States, a phased measurement program is advocated; both countries recommend one or more short-term screening measurements, followed by a confirming long-term measurement (if required).

The Canadian federal government defines a screening test as a radon measurement made in the basement (or lowest level of a house) and capable of producing a result in a few days (Health and Welfare Canada 1989). It recognizes that the screening measurement does not provide a reliable estimate of annual radon exposure, and recommends a six-month long exposure be made in the living area of the house (no preference as to which six months).

The province of Manitoba recommends two-day to several week long screening measurements be made in the lowest livable level of the house. It too recognizes that the screening measurement does not provide a reliable estimate of annual radon exposure, and recommends a three-month long exposure (under closed-house conditions) be made in at least two lived-in areas of the house. The long-term test is to be considered if the screening measurement is about 150 Bq/m³ to 800 Bq/m³, and made if the screening measurement is about 800 Bq/m³ or greater (Government of Manitoba 1989.)

British Columbia dispenses with the screening measurement (Morley 1989); recommending instead a long-term measurement made during a minimum of three heating months. The stated preference is a six to 12 month exposure (Province of British Columbia 1989).

EXPERIMENTAL DESIGN

Households

The project started with 28 single family detached homes with basements, selected at random from across the province of Ontario. Homeowners were solicited by telephone to participate in the research project. Follow-up was by way of confirming letter.

Initial communities in the study included: Arthur, Ayr, Balmertown, Bancroft, Brampton, Cambridge, Conestogo, Deep River, Glen Morris, Guelph, Hamilton, Kanata, Kenora, Kingston, Kitchener, Lively, Mount Brydges, Onaping, Pembroke, Richmond Hill, St. George, Stratford, Waterdown and Waterloo. *Note: Homeowners in Ayr, Balmertown, Brampton, Conestogo, Kanata, Kingston and Lively did not return monitors after the initial seasonal measurement (despite several follow-up calls and letters). The household in Kenora elected to drop out of the program (they felt the questionnaire was too involved) and returned all materials. Some of the non-respondents were replaced by alternate homeowners in Dowling, Pembroke, Timmins and Willowdale.*

The 24 homeowners who did participate in the study were from the communities of: Arthur, Bancroft, Cambridge, Deep River, Dowling, Glen Morris, Guelph, Hamilton, Kitchener, Mount Brydges, Onaping, Pembroke, Richmond Hill, St. George, Stratford, Timmins, Waterdown, Willowdale and Waterloo (see Fig. 2). Information pertaining to specifics of each house tested, e.g., house size, age, construction and heating method was obtained by questionnaire. Householders were also asked to sketch details of their basement floor plan, including: floor area and basement height; the location of drains, floor cracks, sumps and furnace; and indicate the location of the short-term monitor.

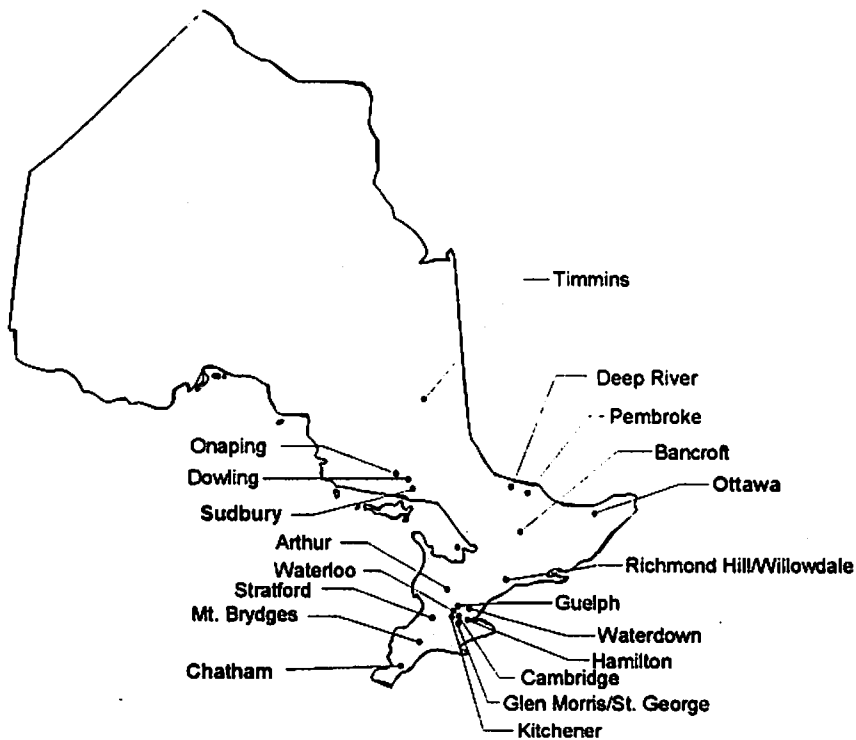

Fig. 2 - Participating Communities (bold entries for reference only)

Radon Monitoring

The first deployment of long-term (annual) and short-term (seasonal) radon monitors, took place in the summer of 1994. The monitors used for both measurements were E-PERMs® (Electret - Passive Environmental Radon Monitor) produced by Rad Elec Inc., Frederick, Maryland.

E-PERMs® or electret ion chambers (EICs), were chosen because the EIC method provides a true integrated measurement of the average radon concentration during the exposure period (EPA 1987, Kotrappa et al 1988). The electret ion chamber is not affected by varying temperatures, air pressure changes or humidity (Fjeld et al 1994, Summers et al 1990), however, environmental gamma radiation makes a small contribution to the voltage drop on the electret and must be measured separately and corrected for.

The short-term monitors consisted of a charged dielectric disc — the electret (polytetrafluoroethylene Teflon for short-term electrets) housed in a type-S ionization chamber (210 ml air volume, conductive plastic canister). The exposed surface of the electret is positive (surface potential is typically in the range of 200 to 750 volts), the surface bonded to the base, and the plastic canister, are negative. See Fig. 3.

The operating principle of the short-term EIC is as follows: The electret ion chamber is activated or turned "ON" by unscrewing its spring loaded cap. This allows airborne radon to diffuse into the monitor through filtered holes in the neck of the chamber. These same filtered holes exclude the entry of radon progeny and other environmental ions (Kotrappa et al 1990). The electret loses

electrostatic potential in direct response to negative ions generated inside the chamber by the decay of radon and its radioactive progeny. The exposure is stopped by screwing down the cap — this action pushes the electret cover down over the electret, effectively sealing it from ions inside the chamber. Once the exposure has stopped, no further voltage drop occurs on the electret. The LLD (LLD is defined as the lowest (radon) level detectable $\pm 50\%$) for short-term electret ion chambers (210 ml air volume) is as follows (Rad Elec Inc 1993):

2 day exposure	LLD = 9.3 Bq/m ³
4 day exposure	LLD = 7.9 Bq/m ³
7 day exposure	LLD = 5.9 Bq/m ³

Short-term EICs were exposed in the basement and main living level of each house tested, for a period of four days during each season (summer, fall, winter and spring). At the start of each season, homeowners received two, sealed short-term electret ion chambers containing pre-measured short-term electrets. They were instructed to establish closed-house conditions (EPA 1993) for at least 12 hours before starting the measurement; and to maintain those conditions for the duration of the short-term measurement. *Note: Homeowners were allowed to use furnaces and air conditioners (provided they were only recirculating interior air) as they normally would.* The EICs were deployed at least 75 cm above the floor or below the ceiling, and at least 10 cm away from other objects. Vents, exterior doors and windows were avoided.

The long-term monitors consisted of a long-term electret (tetrafluoroethylene Teflon) housed in a type-L ionization chamber (50 ml air volume, conductive plastic canister). Unlike the type-S chamber, the type-L chamber does not have an ON/OFF mechanism.

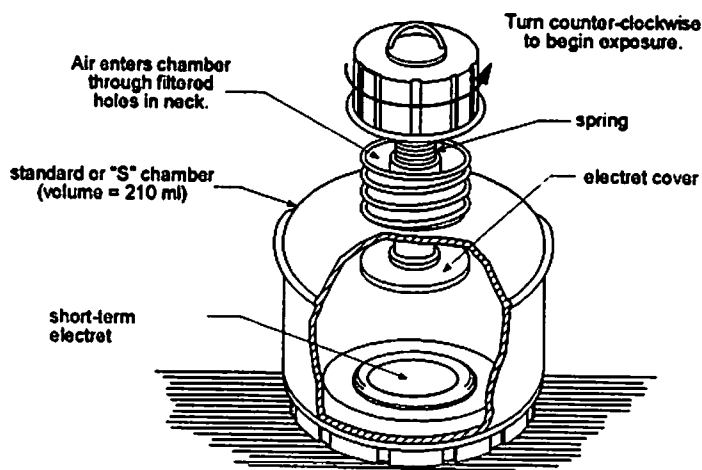

Fig. 3 - The Short-term Monitor

The LLD for long-term electret ion chambers (50 ml air volume) is as follows:

90 day exposure LLD = 11.1 Bq/m³
 365 day exposure LLD = 7.0 Bq/m³.

Homeowners received a pre-measured and capped long-term electret, and a type-L chamber. The long-term test protocol instructed them to quickly remove the cap and install the electret into the chamber to begin the long-term measurement. The long-term EICs were deployed on the main living level of the house. They were positioned at least 75 cm above the floor or below the ceiling, and about 30 cm away from the main floor short-term EIC. See Fig. 4.

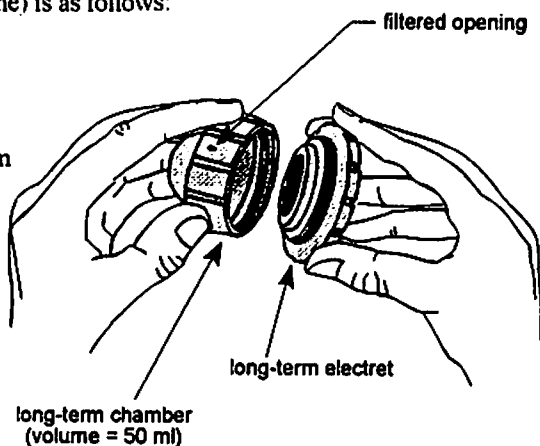

Fig. 4 - The Long-term Monitor

RESULTS

Exposed electret ion chambers were returned via Canada Post to LaFontaine Consulting Services for analysis. Homeowners were instructed to return the long-term monitors with the fourth and last pair of seasonal short-term monitors. The long-term electrets were left in the 50 ml chambers for transit — it was assumed that the electret voltage drop produced by radon exposure during the mail delivery period would have an insignificant impact on the final results, i.e.,

$$\Delta V_{365 \text{ days}} \gg \Delta V_{\text{mail}}$$

Summary Statistics

Test Period	Location	N	geometric mean	arithmetic mean	standard deviation	minimum	maximum
summer	basement	24	168.0	227.6	189.3	62.9	847.3
	main	24	105.0	162.8	162.7	18.5	647.5
fall	basement	23	150.3	201.2	200.9	40.7	936.1
	main	23	123.9	166.3	154.8	29.6	680.8
winter	basement	24	191.3	242.4	216.2	66.6	1028.6
	main	24	144.1	194.1	181.4	33.3	817.7
spring	basement	23	149.6	201.2	204.7	48.1	917.6
	main	23	116.1	151.5	149.9	37.0	714.1
annual	main	24	196.3	247.6	212.9	77.7	895.4

- Notes: 1) means, standard deviation, minimum and maximum values have units of Bq/m³.
 2) the standard deviation is the sample standard deviation, i.e., the square root of the sample variance.
 3) for the houses studied, the occurrence of maximum radon levels was as follows:

Basement — spring 4.5%, summer 36.4%, fall 13.6% and winter 45.5%
 Main — spring 18.2%, summer 18.2%, fall 18.2% and winter 45.4%.

Summer/Annual Summary

house #	basement (B) Bq/m ³	main (M) Bq/m ³	annual (A) Bq/m ³	B/M	B/A	M/A	
1	259.0	307.1	240.5	0.84	1.08	1.28	
2	181.3	506.9	843.6	0.36	0.21	0.60	
3	281.2	162.8	222.0	1.73	1.27	0.73	
4	77.7	170.2	166.5	0.46	0.47	1.02	
5	325.6	55.5	199.8	5.87	1.63	0.28	
6	133.2	111.0	451.4	1.20	0.30	0.25	
7	114.7	166.5	96.2	0.69	1.19	1.73	
8	62.9	92.5	96.2	0.68	0.65	0.96	
9	617.9	440.3	229.4	1.40	2.69	1.92	
10	111.0	55.5	185.0	2.00	0.60	0.30	
11	388.5	40.7	177.6	9.55	2.19	0.23	
12	151.7	29.6	114.7	5.13	1.32	0.26	
13	122.1	96.2	107.3	1.27	1.14	0.90	
14	77.7	103.6	140.6	0.75	0.55	0.74	
15	292.3	136.9	266.4	2.14	1.10	0.51	
16	199.8	125.8	173.9	1.59	1.15	0.72	
17	111.0	59.2	155.4	1.88	0.71	0.38	
18	281.2	77.7	388.5	3.62	0.72	0.20	
19	395.9	296.0	325.6	1.34	1.22	0.91	
20	210.9	99.9	159.1	2.11	1.33	0.63	
21	66.6	18.5	107.3	3.60	0.62	0.17	
22	847.3	647.5	895.4	1.31	0.95	0.72	
23	85.1	66.6	122.1	1.28	0.70	0.55	
24	66.6	40.7	77.7	1.64	0.86	0.52	
				mean	2.18	1.03	0.69
				count	24	24	24
				min.	0.36	0.21	0.17
				max.	9.55	2.69	1.92

Note: Houses 2 and 9 were both in Pembroke yet the annual radon concentration in house #2 was 3.7 times greater than that measured in house #9.

Fall/Annual Summary

house #	basement (B) Bq/m ³	main (M) Bq/m ³	annual (A) Bq/m ³	B/M	B/A	M/A	
1	151.7	118.4	240.5	1.28	0.63	0.49	
2	192.4	107.3	843.6	1.79	0.23	0.13	
3	66.6	51.8	222.0	1.29	0.30	0.23	
4	107.3	125.8	166.5	0.85	0.64	0.76	
5	192.4	173.9	199.8	1.11	0.96	0.87	
6	599.4	484.7	451.4	1.24	1.33	1.07	
7	62.9	81.4	96.2	0.77	0.65	0.85	
8	144.3	48.1	96.2	3.00	1.50	0.50	
9	333.0	262.7	229.4	1.27	1.45	1.15	
10	40.7	29.6	185.0	1.38	0.22	0.16	
11	***	***	177.6	***	***	***	
12	144.3	107.3	114.7	1.34	1.26	0.94	
13	99.9	88.8	107.3	1.13	0.93	0.83	
14	162.8	366.3	140.6	0.44	1.16	2.61	
15	262.7	233.1	266.4	1.13	0.99	0.88	
16	107.3	129.5	173.9	0.83	0.62	0.74	
17	151.7	129.5	155.4	1.17	0.98	0.83	
18	74.0	66.6	388.5	1.11	0.19	0.17	
19	155.4	166.5	325.6	0.93	0.48	0.51	
20	111.0	70.3	159.1	1.58	0.70	0.44	
21	92.5	70.3	107.3	1.32	0.86	0.66	
22	936.1	680.8	895.4	1.38	1.05	0.76	
23	333.0	144.3	122.1	2.31	2.73	1.18	
24	107.3	88.8	77.7	1.21	1.38	1.14	
				mean	1.30	0.92	0.78
				count	23	23	23
				min.	0.44	0.19	0.13
				max.	3.00	2.73	2.61

Note: Personal schedule of household #11 prevented timely deployment of the fall short-term monitors.

The summer/annual and fall/annual summary tables show a mean basement screening : annual radon measurement ratio of 1.03 for the summer, and 0.92 for the fall. Mean basement screening : main floor screening radon measurements for the same two seasons was 2.18 for the summer and 1.30 for the fall.

Results of the annual radon measurement (column 4 on all summary tables) are summarized as follows:

- 8/24 or 33.3% of the measurements were less than the U.S. EPA action level of 148 Bq/m³ (4 pCi/L)
- 16/24 or 66.7% of the measurements exceeded the U.S. EPA action level of 148 Bq/m³ (4 pCi/L)
- 2/24 or 8.3% of the measurements exceeded the "recommended" Canadian guideline of 800 Bq/m³
- 22/24 or 91.7% of the measurements were less than the "recommended" Canadian guideline of 800 Bq/m³.

Fig. 5 is a graph of the annual living area radon measurement versus the summer basement radon measurement for each house. The spread in the data is expected due to the small sample size and diverse geologies of the test localities.

Linear regression analysis produced a slope (annual Rn : summer basement Rn) = 1.0 ± 0.30 . The value of the coefficient of determination ($r^2 = 0.335$) indicates that for the study data, 33.5% of the variability in annual radon concentrations is explained by the variability in summer radon screening measurements. The remaining 66.5% is unexplained.

Fig. 6 shows the graph of the annual living area radon measurement versus the fall basement radon measurement for each house. Linear regression analysis produced a slope (annual Rn : fall basement Rn) = 1.0 ± 0.24 . The value of the coefficient of determination ($r^2 = 0.444$) indicates that for the study data, 44.4% of the variability in annual radon concentrations is explained by the variability in fall radon screening measurements; 55.6% is unexplained.

The frequency distribution histograms in Figs. 7 and 8, show the percent occurrence for the basement/annual radon measurement ratios.

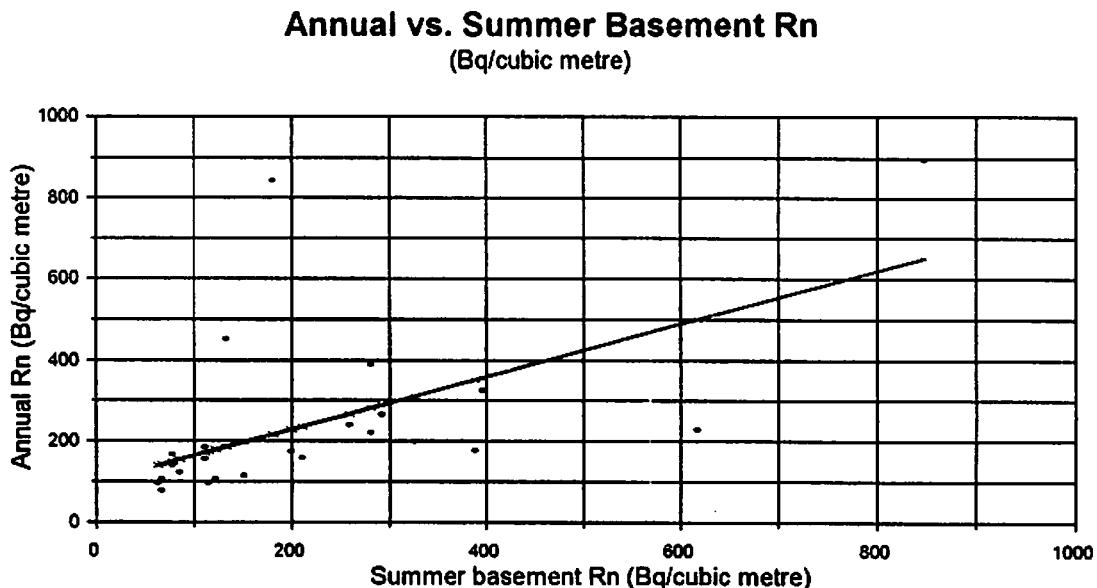

Fig. 5

Annual vs. Fall Basement Rn (Bq/cubic metre)

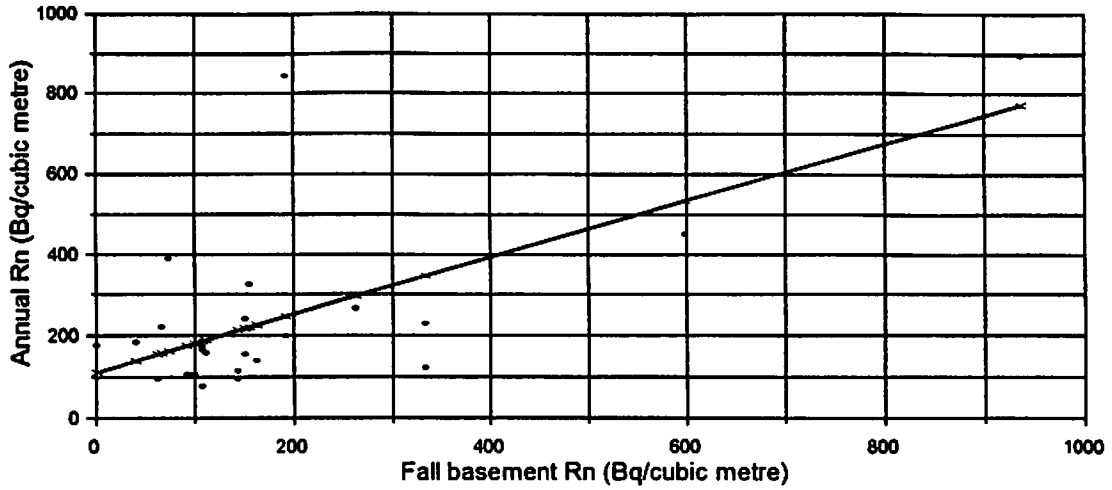

Fig. 6

Summer & Annual Rn Measurements basement/annual ratio vs. % occurrence

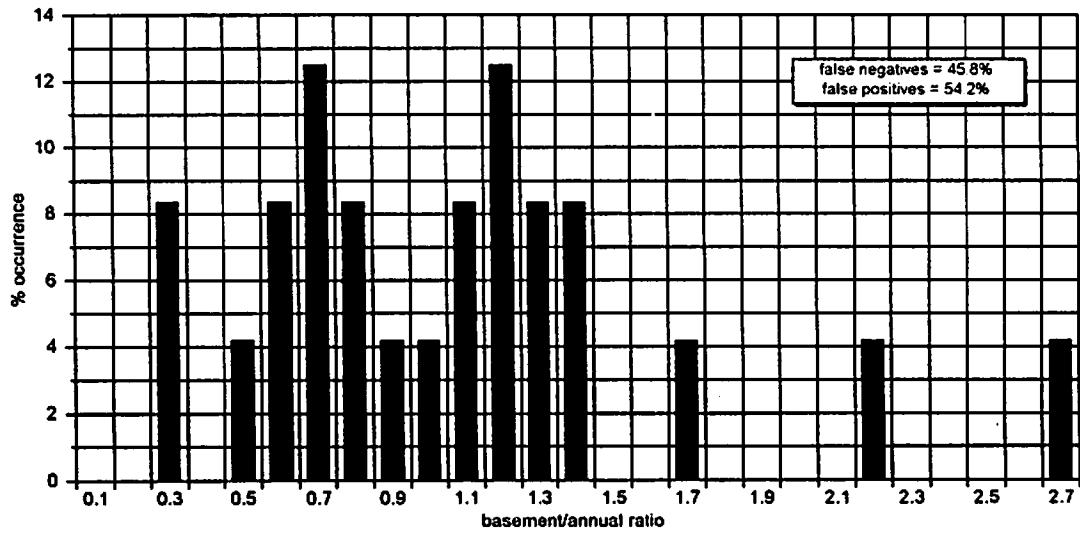

Fig. 7

Fall & Annual Rn Measurements
basement/annual ratio vs. % occurrence

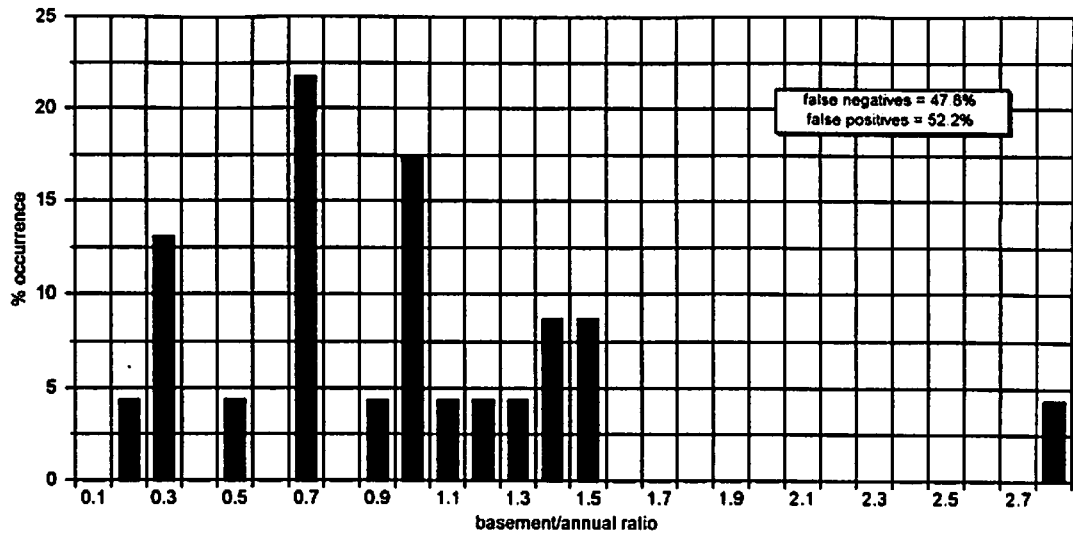

Fig. 8

Winter/Annual Summary

house #	basement (B) Bq/m ³	main (M) Bq/m ³	annual (A) Bq/m ³	B/M	B/A	M/A	
1	218.3	233.1	240.5	0.94	0.91	0.97	
2	270.1	92.5	843.6	2.92	0.32	0.11	
3	173.9	111.0	222.0	1.57	0.78	0.50	
4	214.6	218.3	166.5	0.98	1.29	1.31	
5	236.8	192.4	199.8	1.23	1.19	0.96	
6	732.6	621.6	451.4	1.18	1.62	1.38	
7	66.6	55.5	96.2	1.20	0.69	0.58	
8	85.1	33.3	96.2	2.56	0.88	0.35	
9	281.2	199.8	229.4	1.41	1.23	0.87	
10	151.7	140.6	185.0	1.08	0.82	0.76	
11	103.6	40.7	177.6	2.55	0.58	0.23	
12	129.5	103.6	114.7	1.25	1.13	0.90	
13	111.0	99.9	107.3	1.11	1.03	0.93	
14	251.6	244.2	140.6	1.03	1.79	1.74	
15	273.8	162.8	266.4	1.68	1.03	0.61	
16	155.4	185.0	173.9	0.84	0.89	1.06	
17	203.5	192.4	155.4	1.06	1.31	1.24	
18	399.6	358.9	388.5	1.11	1.03	0.92	
19	177.6	203.5	325.6	0.87	0.55	0.63	
20	229.4	111.0	159.1	2.07	1.44	0.70	
21	77.7	66.6	107.3	1.17	0.72	0.62	
22	1028.6	817.7	895.4	1.26	1.15	0.91	
23	129.5	81.4	122.1	1.59	1.06	0.67	
24	114.7	92.5	77.7	1.24	1.48	1.19	
				mean	1.41	1.04	0.84
				count	24	24	24
				min.	0.84	0.32	0.11
				max.	2.92	1.79	1.74

Spring/Annual Summary

house #	basement (B) Bq/m ³	main (M) Bq/m ³	annual (A) Bq/m ³	B/M	B/A	M/A	
1	185.0	114.7	240.5	1.61	0.77	0.48	
2	148.0	107.3	843.6	1.38	0.18	0.13	
3	236.8	199.8	222.0	1.19	1.07	0.90	
4	129.5	151.7	166.5	0.85	0.78	0.91	
5	233.1	173.9	199.8	1.34	1.17	0.87	
6	677.1	451.4	451.4	1.50	1.50	1.00	
7	81.4	74.0	96.2	1.10	0.85	0.77	
8	92.5	66.6	96.2	1.39	0.96	0.69	
9	321.9	185.0	229.4	1.74	1.40	0.81	
10	48.1	37.0	185.0	1.30	0.26	0.20	
11	85.1	81.4	177.6	1.05	0.48	0.46	
12	144.3	96.2	114.7	1.50	1.26	0.84	
13	62.9	66.6	107.3	0.94	0.59	0.62	
14	92.5	148.0	140.6	0.63	0.66	1.05	
15	299.7	125.8	266.4	2.38	1.13	0.47	
16	173.9	222.0	173.9	0.78	1.00	1.28	
17	170.2	107.3	155.4	1.59	1.10	0.69	
18	107.3	55.5	388.5	1.93	0.28	0.14	
19	***	***	325.6	***	***	***	
20	151.7	77.7	159.1	1.95	0.95	0.49	
21	85.1	85.1	107.3	1.00	0.79	0.79	
22	917.6	714.1	895.4	1.28	1.02	0.80	
23	99.9	74.0	122.1	1.35	0.82	0.61	
24	85.1	70.3	77.7	1.21	1.10	0.90	
				mean	1.35	0.87	0.69
				count	23	23	23
				min.	0.63	0.18	0.13
				max.	2.38	1.50	1.28

Note: Personal schedule of household #19 prevented timely deployment of the spring short-term monitors.

The winter/annual and spring/annual summary tables show a mean basement screening : annual radon measurement ratio of 1.04 for the winter, and 0.87 for the spring. Mean basement screening : main floor screening radon measurements for the same two seasons was 1.41 for the winter and 1.35 for the spring.

In Fig. 9, the annual living area radon measurement versus the winter basement radon measurement for each house is graphed. Here, linear regression analysis produced a slope (annual Rn : winter basement Rn) = 1.0 ± 0.18 . The value of the coefficient of determination ($r^2 = 0.594$) indicates that for the study data, 59.4% of the variability in annual radon concentrations is explained by the variability in winter radon screening measurements. The remaining 40.6% must be explained by other factors.

Fig. 10 is a graph of the annual living area radon measurement versus the spring basement radon measurement for each house. Linear regression analysis produced a slope (annual Rn : spring basement Rn) = 1.0 ± 0.25 . The value of the coefficient of determination ($r^2 = 0.425$) indicates that for the study data, 42.5% of the variability in annual radon concentrations is explained by the variability in spring radon screening measurements; 57.5% is unexplained.

The frequency distribution histograms in Figs. 11 and 12, show the percent occurrence for the basement/annual radon measurement ratios.

The false positives and false negatives (referenced to the annual measurement) for each season, are tabled as follows:

Season	False Negatives	False Positives
summer	45.8%	54.2%
fall	47.8%	52.2%
winter	37.5%	62.5%
spring	47.8%	52.2%

Annual vs. Winter Basement Rn (Bq/cubic metre)

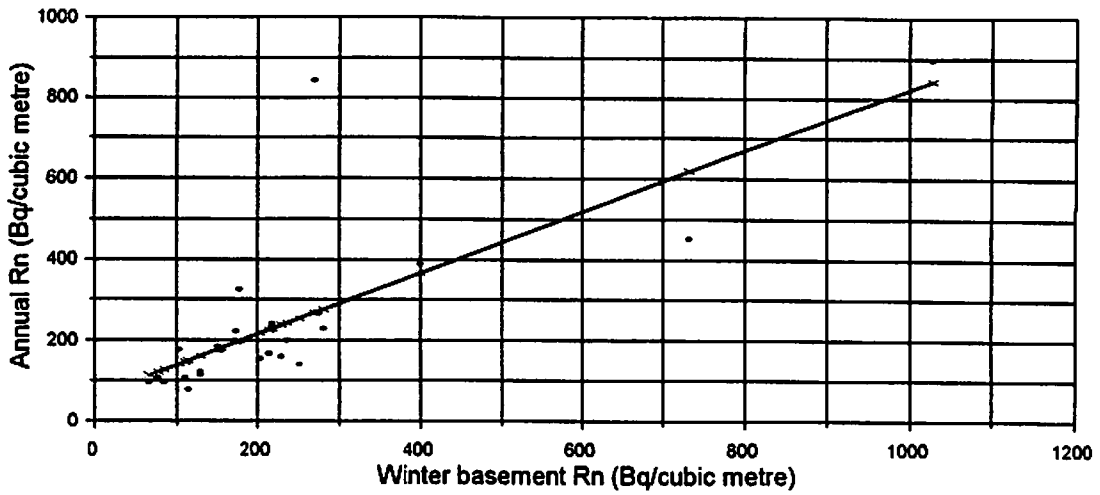

Fig. 9

Annual vs. Spring Basement Rn (Bq/cubic metre)

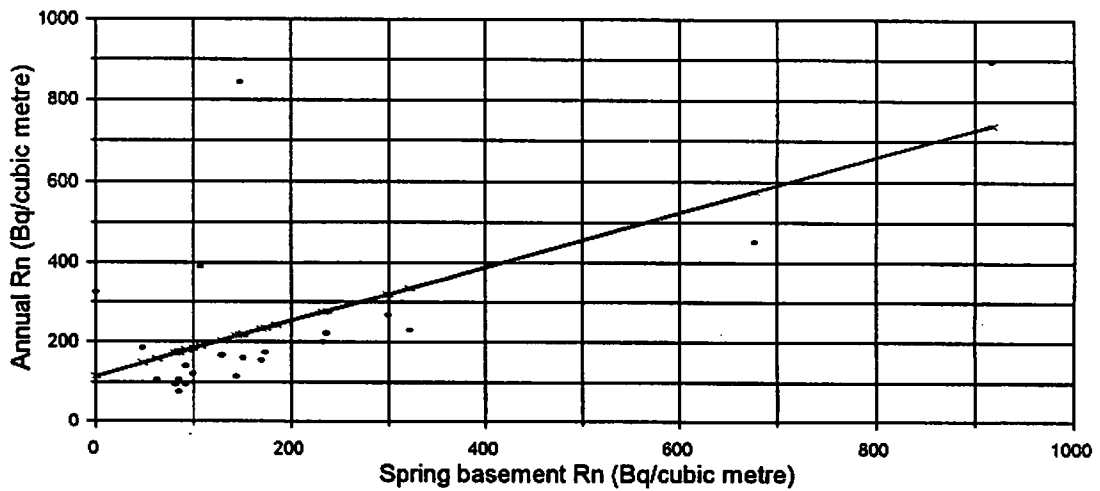

Fig. 10

Winter & Annual Rn Measurements
 basement/annual ratio vs. % occurrence

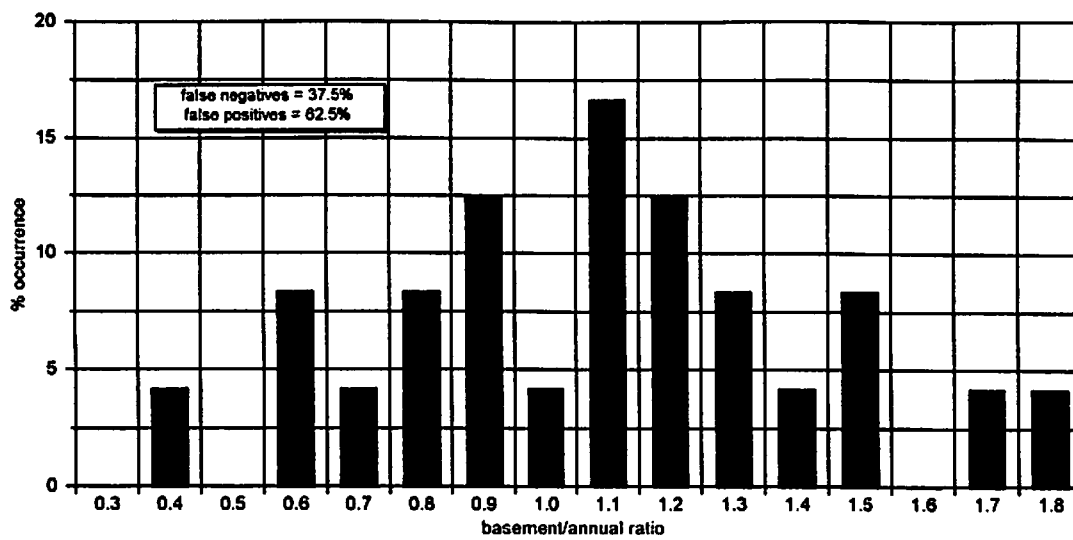

Fig. 11

Spring & Annual Rn Measurements
 basement/annual ratio vs. % occurrence

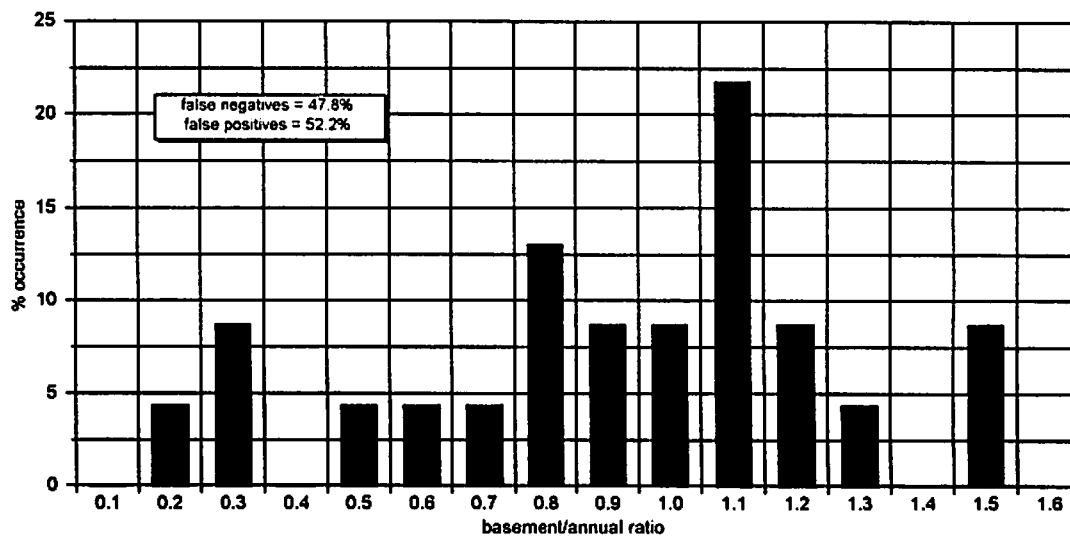

Fig. 12

CONCLUSIONS

A study was conducted to evaluate the radon screening measurement as an indicator of average annual indoor radon exposure. Data for the study was obtained from 24 single family detached homes from across the province of Ontario, Canada.

The study indicates:

- 1) The short-term screening measurement is not an accurate indicator of annual indoor radon exposure. Regardless of season, there exists a 50-50 chance that the screening measurement will actually be a false negative or false positive.
- 2) Guidelines or action levels based on annual radon exposure should not be used as the criteria for short-term screening measurements. A scaled criteria based on both the annual exposure level guideline target and the duration of screening measurement period should be implemented.
- 3) Instantaneous or grab sample readings should not be used as a basis for estimating annual indoor radon exposure.
- 4) Peak radon values may occur in any season, though winter exhibits the highest number.
- 5) Indoor radon levels can be extremely variable within the same community. Confounding factors include: house construction — nature of underlying fill material, proximity to and nature of bedrock, presence of exposed earth (sump pits, crawl spaces), condition of foundation, etc.; house location — urban versus rural; lifestyles - ventilation type and frequency of use, nature and usage of depressurizing devices, e.g., basement fireplaces, clothes dryers.
- 6) Electret ion chambers are easy to deploy by the homeowner, and are small enough to facilitate postal delivery.

REFERENCES

- Cothorn, C.R., Smith, J.E. (editors), Environmental Radon, Plenum Press, New York, 1987.
- EPA, Operational Evaluation of Electret Passive Environmental Radon Monitor, US Environmental Protection Agency, Internal Report, Las Vegas, 1987.
- EPA, Protocols for Radon and Radon Decay Product Measurements in Homes, US Environmental Protection Agency, EPA 402-R-93-003, Washington D.C., 1993.
- Fjeld, R.A., Montague, K.J., Haapala, M.H., Kotrappa, P., Field Test of Electret Ion Chambers for Environmental Monitoring, Health Physics, Vol. 66, No. 2, 1994.
- Government of Manitoba, Radon: An Interim Guide for Manitoba Homeowners, Winnipeg, 1989.
- Health and Welfare Canada, Radon: You and Your Family - A Personal Perspective, Supply and Services Canada, Ottawa, 1989.
- Kotrappa, P., Dempsey, J.C., Hickey, J.R., Stieff, L.R., An Electret Passive Environmental ²²²Radon Monitor Based on Ionization Measurement, Health Physics, Vol. 54, No. 1, 1988.
- Kotrappa, P., Dempsey, J.C., Ramsey, R.W., Stieff, L.R., A Practical E-PERM™ (Electret Passive Environmental Radon

Monitor) System for Indoor ²²²Rn Measurement, Health Physics, Vol. 58, No. 4, 1990.

Krewski, D., Miller, T., Eaton, R.S., Meyerhof, D.P., Létourneau, E.G., Managing Environmental Radon Risks: A Canadian Perspective, Management of Risk from Genotoxic Substances in the Environment, Swedish National Chemicals Inspectorate, Stockholm, 1989.

Lafavore, M., Radon: The Invisible Threat, Rodale Press, Emmaus, 1987.

Morley, D.R., Phillips, B.G., Predicting Radon Gas Levels in B.C. Homes, British Columbia Ministry of Health - Radiation Protection Service, Vancouver, 1989.

Province of British Columbia, Radon Testing in British Columbia, Vancouver, 1989.

Rad Elec Inc., The E-PERM[®] System Manual, Rad Elec Inc., Frederick, 1991-1993.

Summers, J.R., Nicholas, W.D., Clemons, R.L., Comparison of the Electret-Passive Radon Monitor System with Charcoal Canisters in Controlled Environments, The 1990 International Symposium on Radon and Radon Reduction Technology, Preprints, EPA/600/9-90/005b, 1990.

Thomas, R., Radon's Troublesome Daughters Stir up Controversy, AECL Ascent, Vol. 8, No. 2, 1989.

Townsend, M.G., CANMET Technology Leads to Commercial Development of Instruments to Monitor Radon in Mines and Houses, GEOS, Vol. 18, No. 4, 1989.