

**AN INEXPENSIVE METHOD OF ACCURATELY MEASURING THE
AVERAGE RADON CONCENTRATION IN A RADON TEST CHAMBER
OR IN THE FIELD**

C. Distenfeld & L. Distenfeld
TCS Industries Inc.
4326 Crestview Road
Harrisburg, PA 17112

INTRODUCTION

The radon measurement industry is primarily interested in radon risk to inhabitants in homes and work places. Since health risk accumulates with time, longer term measurements are more important than instantaneous radon assays. Accurate measurements of the average radon concentration over days and years is complicated by the variation of radon concentration with time. Three mechanisms that most perturb the radon concentration are the well known diurnal radon concentration cycle, dilution by drafts, and normal radioactive decay.

Radon measurements are usually performed by three types of detectors. They are electronic instruments that continuously sample the radon concentration, record each value in memory, and calculate the average at the end of the exposure. Integrators such as Eperms, or alpha track devices, or semi-integrators such as activated charcoal detectors are more routinely used. For calibration purposes electronic continuous radon detectors are frequently used to precisely define the exposure fields that the other detectors are tested in. The quality of these test exposures depends on the calibration and stability of the continuous radon measuring device used to define the radon field. Good calibration facilities deploy more than one continuous monitors to confirm the results, and the devices must be calibrated at least annually.

A better type of continuous monitor should contain a radon source that could be used to standardize the instrument to eliminate short and long term errors. Some Lucas cells are made with internal radium sources such as the Pylon 3150A calibrator. Evacuated Lucas cells are frequently used for short term 'grab' samples to determine near instantaneous radon concentrations. If it were possible to accumulate an air sample composed of many smaller samples taken over time that were compensated for decay, one or more Lucas cells could be used to measure the average radon concentration over several days with accuracy and precision rivaling electronic instruments and exceeding continuous monitors by the ability to normalize to a radium doped Lucas cell. This purpose of this paper is to describe such a system.

THEORY

For any sample 'i' of air or gas containing radon the amount of radioactivity is:

$$A_i = C_i \times V_i$$

Where C is the radon concentration in picoCuries per liter, pCi/l, and V is the sample volume in liters, l. After time T:

$$A_T = A_i e^{-\lambda T}$$

For n samples pumped to some container and summing from one to n:

$$\Sigma A_T = \Sigma A_i e^{-\lambda(T-t_i)}$$

The total of A sub T increments is composed of samples of uncertain radioactive content; since radon varies with time. The total is further perturbed since each increment underwent a different amount of radioactive decay leading to a total sample that does not reflect the original exposure. The purpose of this paper is to describe a method to exactly compensate for these uncertainties. What is required is a system of samples that retain the original individual radioactivity at a given time such as the end of a test exposure. This is easily accomplished by increasing each sampling volume to contain additional radon activity to exactly compensate for radioactive decay to a reference time such as the end of the test.

$$\Sigma A_i = \Sigma C_i e^{-\lambda(T-t_i)} \times V_i e^{\lambda(T-t_i)}$$

$$\Sigma A_i = \Sigma A_i e^0 \tag{5}$$

But remember:

$$V_T = \Sigma V_i e^{\lambda(T-t_i)} = \Sigma V_i$$

Since no radon loss was attributed to leakage from the gas bag, lambda = 0.

The concentration of radon in the sampling container at the end of the exposure is:

$$\Sigma C_T = \Sigma A / V_T$$

However the sampling volume is known and can be used to adjust the physical concentration to the total concentration due to the average concentration for the test exposure.

$$\Sigma C_i = \frac{\Sigma A_i}{V_T} \times \frac{V_T}{\Sigma V_i} = \Sigma C_T \times \frac{V_T}{\Sigma V_i} = \Sigma C_T \times \text{CONSTANT}$$

The constant is nothing more than the ratio of the total adjusted volume to the unadjusted volume. For a pump set for constant flow rate, the same constant is the total adjusted flow time to the total, baseline, unadjusted flow time.

HARDWARE

From the foregoing, it is clear what is needed is a means to control sample volume. A computer used to drive a sampling pump is a logical choice. Software can automatically and exactly adjust each sample flow duration for any number of total increments comprising the total sample.

Figure 1, is a schematic representation of the sampling system. A small pump capable a flow rate between 0.3 and 0.5 liters/minute, l/m, is convenient. This can be a battery powered diaphragm pump or a small air pump used to aerate fish tanks. If a fish tank air pump is used, the pump must be placed within the sampled environment. Diaphragm pumps with separate inlet and outlet connections allow greater flexibility. A check valve is not shown but may be needed if the sampled environment is at a slightly higher pressure than the sampling bag. For significant pressure differentials, a electrically operated valve is suggested.

A flow meter was used to adjust flow, to verify consistent flow rate, and to not over fill the gas sampling bag. Plastics are known to be permeable to gases including radon. A 20 liter 4 mil thick Tedlar gas sampling bag was obtained from the Cole-Parmer Instrument Co. The bag was tested before use. The bag was filled with air containing about 12.5 pCi/l of radon. Four minutes after filling, an evacuated 0.3 liter Lucas cell was used to draw a sample from the bag. This was repeated once per day for the next 5 days. Within a measurement uncertainty of 2.7%, no loss was observed not accounted for by radioactive decay. The Cole-Parmer catalog contained gas permeability data for plastic tubing. The data were for carbon dioxide, hydrogen, oxygen, and

nitrogen. Different plastic tubing had permeability values that varied by more than a factor of one thousand; which required care in selection of tubing material. The authors used copper refrigeration tubing where ever possible. The 1/8 inch OD tubing had an internal volume of <4 cc per meter of length. For a minimum flow rate of 0.3 l/m and minimum time of 20 seconds, the tubing trapped less than 4% of a minimum sample increment. Of course the trapped volume is not lost, but transferred by the next sample.

Any computer with an internal speaker can be used that is able to run a compiled quick basic program. The author employed a 286 computer assembled in 1986; an audio output was needed but a sound card was not. Simplicity and economy were motivating factors in the design of the sampling system. Employing an electrical signal taken from the computer speaker terminals, and using the standard DOS operating system minimized changes to the computer. A small external interface was designed to drive the air pump, Figure 2. The band pass of the input transformer may be limited. The authors suggest testing with tones of different frequency for solid operation of the driver; 600 Hz was used for the driver. The driver exhibited a 2 second dwell time after the audio signal, and this was compensated for by software. All of the components were readily available from Radio Shack.

SOFTWARE

Figure 3, is a printout of the Quick Basic 4.5 code that was used to operate the sampler. The code was compiled, with all libraries, and the exe. File was placed on the 'C' drive of a computer. Typing the name of the execute file loaded, started the program, and displayed the options shown as input statements on Figure 3. The user can choose to print out the stating time and date, cycle time for each incremental sample, an identifier for the measurement, and to select the duration of the test in days. The operating kernel is the Basic statement:

SOUND frequency, duration

Where the frequency can be varied from 32 to 32767 Hz, and the duration from 0 to 65535 ticks. To convert ticks to seconds divide by 18.2 tick per seconds. The statement,

$$t = 18.2 * 20 * \text{EXP}(.693 * (\text{dys} - (\text{numr}/(60*24)))/3.84)$$

calculates the number of BASIC ticks required for any increment. During the last cycle the tone is turned on for the minium time of 20 seconds; since both dys and numr = 0. For any other time, the cycle time is increased to exactly compensate for radioactive decay of radon. The half life of radon was taken to be 3.84 days, and lambda was 0.693/3.84 per day.

DISCUSSION

The quality of this sampling system was related to the quality of the Lucas cells and associated readout electronics. Two Pylon 300A cells and an AB-5 instrument were tested by filling the cells from a fixed concentration of radon contained in the gas bag. The time difference for filling the first to last cell was less than 2 minutes; hence the radon concentration in the cells was taken to be the same. Two minutes of radioactive decay is too small a difference to measure. The 2 cells were counted sequentially by normal mounting and dismounting the individual cells from the Pylon AB-5 instrument. After the first counting cycle the cells were remounted and counted again a day later. This was repeated for 3 counting cycles for each of the 2 Lucas cells over a period of two days. Correcting for decay, cell #841 had a measured repeatability of +/- 0.8% and cell #842 was 2.3%. Apart from errors associated with the original cell calibrations, it was concluded from this test and from the earlier mentioned gas bag leakage test that it was realistic to expect measurement uncertainties to be less than about 3% for radon fields of slowly varying concentration. Longer term errors resulting from changes in the Lucas cells or the AB-5 instrument are reduced to small values by using a sealed radium doped Lucas cell, Pylon model 3150A. The calibration cell is routinely counted before and after every measurement set, and the average used to adjust the results of radon determination. Long term changes in the calibration cell are corrected for buildup of Po-210. Intercomparison measurements are also made annually to verify the consistent quality of the Lucas cell system..

The TCS radon test chamber is a one pass flow through system with an adjustable air change time of >15 minutes to < 4 minutes. Radon is derived from a flow through 102 kBq radium cell, Pylon model 1025. Flow meters separately monitor the air flow through the Pylon radon cell nominally operated at 0.8 l/m and in the much larger dilution stream. Pressure measurements are used to insure the chamber is operated slightly above ambient pressure to eliminate unmonitored dilution as any leakage is to the outside.. Routine air flow, humidity and temperature measurements are made. A radon calibration system has been in service since 1986; several months before TCS started a commercial radon measurement business. Over this extended period, reproducible flow rates and corresponding radon concentrations were routinely observed.

This consistency was helpful in evaluating the gas bag sampling system. Tests were conducted over 2 to 4 day accumulations by drawing 2 or more Lucas cell samples directly from the test chamber each day. At the end of the exposure, Lucas cell samples were also drawn from the gas bag. The measured radon concentration ratio of the test chamber to the gas bag closely compared to the value predicted by calculations. A Honeywell continuous radon monitor was also deployed in the test chamber. The standard deviation of the hourly data derived from the Honeywell greatly exceeded the uncertainty associated with the Lucas cell data taken at the same time; so the Honeywell data could not be used reliably for a proof of principal. The predicted ratio is easily calculated with a spread sheet program such as Lotus. The sample duration for each hourly step at constant flow rate is adjusted by:

$$\text{EXP}(\lambda * (T-t))$$

Where lambda is $0.693/(\text{radon half life})$, T is the total exposure time, and t is the time remaining for the test. The ratio is the number of steps divided by the sum of the above adjusted value. Calculated ratios are 0.81 and 0.745 for 48 and 72 hours exposures. The true average exposure in the radon test chamber is therefore the concentration determined in the gas bag by one or more Lucas cells divided by the ratio appropriate for the duration of the exposure..

The gas bag sampling system is routinely used to determine average radon concentrations during 2,3, and 4 day radon 'spike' exposures for activated charcoal detectors. The following is a partial copy of a printout made during an activated charcoal detector spike exposure:

08-02-1999	Sample is 3 days	Spike G cans start 8/2/99
Start time 13:51:48		
Cycle hour = 1		Cycle length in sec. = 34.1
Cycle hour = 2		Cycle length in sec. = 33.9
Cycle hour = 3		Cycle length in sec. = 33.6
⋮		⋮
Cycle hour = 70		Cycle length in sec. = 20.3
Cycle hour = 71		Cycle length in sec. = 20.2
Cycle hour = 72		Cycle length in sec. = 20.0

Use of the gas bag sampling system in unknown radon fields of varying concentration is also possible. Four model radon fields were tested mathematically. The first was a sinusoidally varying field with one maximum of 5 and a minimum of 1 pCi/l per 24 hour period.

$$\text{pCi/l} = 3 + \sin(t * \pi / 12)$$

The second was a radon concentration determined by a random number generator that varied from 0 to 1 pCi/l. The third was a monotonically decreasing radon concentration starting at 10 and declining to 1 pCi/l over 48 hours.

$$\text{Pci/l} = -(9/48)t + 10$$

The last case was six sequential fields of constant radon concentration as follows:

Radon concentration, pCi/l	Duration, hrs
10	14
7	5
3	5
15	4
20	8
6	12

For the sinusoidal, random, and triangular cases the mathematical samples were taken on the hour. For the six box case the sampling was retarded by 15 minutes except for the final sample; to not exactly correspond to the changing field. The results were:

Field Description	Ratio
TCS chamber	0.81
Sinusoidal	0.815
Random	0.80 to .89
Triangular	0.79
Six boxes	0.83

The random case varies whenever a change is made on the spread sheet, as the random series is replaced with a new series. This extreme case represents larger more rapid changes than are usual for the environment. Sinusoidal changes probably reflect the real environment best.

CONCLUSION

Lucas cell detectors, normally classified as grab samplers, can be used for radon measurements extended over several days. When Lucas cells are used with a programable gas bag sampler, measurement precision better than 5% are not difficult to achieve. Absolute accuracy depends on the calibration of the Lucas cells, the radon concentration variation with time, and the number of sampling steps during a determination. For slowly varying radon fields, it was concluded the programable gas bag system could reliably be used to determine the average radon concentration over several days with a precision of < 5%. Further, the system could be used to measure the average radon concentration anywhere with an additional uncertainty of about 3 %.

The cost of all of the components was estimated to be < 300\$ exclusive of the Lucas cell system.

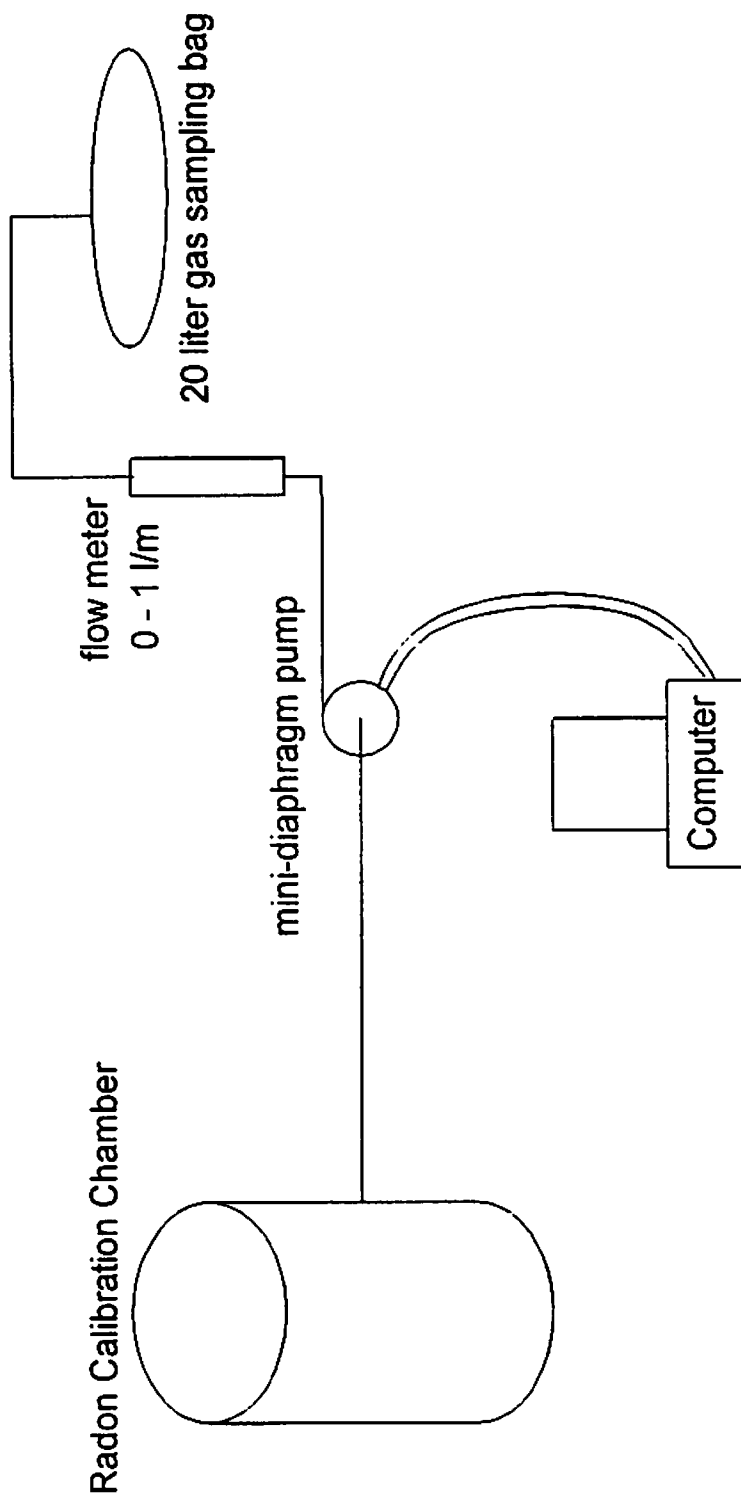

Figure 1, Gas Bag Sampling Device

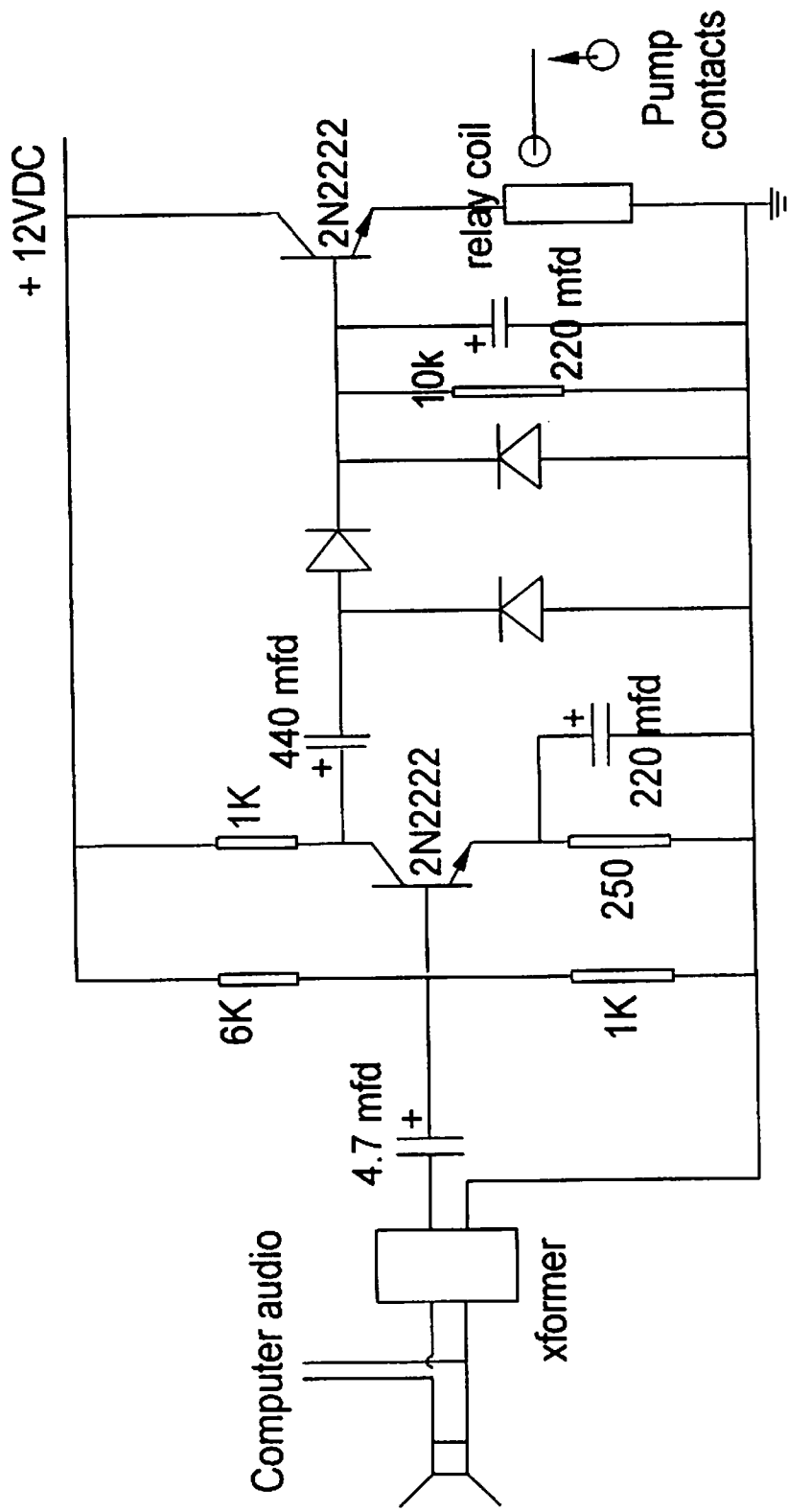

Figure 2, Pump Driver

```

CLS
DEM id AS STRING
numr = 0: min = 0
INPUT "To printout cycles type 'P' or type enter for no printout";p$
IF p$ = "p" OR p$ = "P" THEN p = 1 ELSE p = 0
CLS
INPUT " Enter gas bag accumulation time in days", dys: CLS
INPUT "Identify this test"; id$: CLS
LOCATE 1, 1: PRINT DATES,
PRINT USING " # day sample "; dys;
PRINT id$
LOCATE 15, 15: PRINT " Type lower case 'x' to end test early"
IF p = 1 THEN LPRINT DATES
IF p = 1 THEN LPRINT USING " Sample is # days "; dys;
IF p = 1 THEN LPRINT id$: LPRINT "Start time "; TIMES$: LPRINT

total = dys * 60 * 24
TIMER ON
ON TIMER (60) GOSUB Display
DO WHILE INKEY$ <> "x": LOOP
END

Display:
    Oldrow = CSRLIN           'Save current row.
    Oldcol = POS(0)           'Save current column.
    LOCATE 3, 3: PRINT "The time is "; TIMES
    alarm$ = MIDS(TIMES, 4, 5)
    GOSUB tone
    LOCATE Oldrow, Oldcol ' Restore row & column.

RETURN

tone
    numr = numr + 1: min = min + 1
    LOCATE 4, 3: PRINT "minutes are"; min
    IF min >= 60 THEN min = 0 ELSE RETURN
    t = 18.2 * 20 * EXP(.693 * (dys - (numr / (60 * 24))) / 3.84)
    LOCATE 6, 1: PRINT "Cycle hr. "; numr / 60,
    LOCATE 6, 30: PRINT USING "t= ###.##"; t
    IF p = 1 THEN LPRINT " Cycle hour = "; numr / 60,
    IF p = 1 THEN LPRINT USING " Cycle length in sec. = ##.##"; t / 18.2
    tc = (t - 36.4) ' to correct for 2 seconds lag at end of each cycle
    SOUND 600, tc
    IF numr >= total THEN END

RETURN

'      Program by      Carl Distenfeld
'
'                      TCS Industries Inc.
'                      Harrisburg, PA 17112

```

FIGURE 3, Program software