

Experimental Measurements On The Permeability Coefficient Of A Concrete Sample Under Low Pressure Differences

Laura J. Ferguson, Wessam Z. Daoud and Kevin J. Renken
University of Wisconsin-Milwaukee
Mechanical Engineering Department
Radon Reduction Technology Laboratory
3200 North Cramer Street
Milwaukee, WI 53211
USA

ABSTRACT

Past experimental data on the permeability of concrete has precluded realistic radon entry conditions. This paper presents experimental results on the air permeability coefficient of a standard concrete sample that has been subjected to constant low-pressure differences of 5 – 15 Pa under controlled conditions. An innovative closed-loop PC-data acquisition and control system is utilized to measure the air permeability coefficient of a standard concrete sample. Proportional needle valves, highly accurate pressure transducers and a sophisticated data acquisition and control software package are employed in the control system to monitor and maintain constant pressure conditions. A concrete sample, 4" in length, 3.5" in diameter of standard 1:2:4 composition (cement:sand:gravel), and a water:cement ratio of 0.5, was utilized in the experimentation. Details of the innovative experimental setup and procedures are described as well as a comparison between current and past results is presented.

INTRODUCTION

The permeability of concrete describes its ability to transport a fluid through it by the advection process. Here, the driving force for the transport is the pressure difference that exists across the medium. There have been a number of studies pertaining to the measurement of permeability coefficient in concrete which include: Nielson and Rogers (1991), Rogers and Nielson (1992), Scott (1993), Rogers et al. (1994), Snoddy (1994), Renken and Rosenberg (1995), Sanjuan and Munoz-Martialay (1995, 1996, 1997), Maas and Renken (1997), Lambert and Renken (1999), and Abraham et al. (2000).

Research on the radon gas transport phenomenon has suggested that at relatively low indoor concentrations, the diffusion process is responsible for 80% while the advection process is responsible for 20% of the radon that enters a building from the soil (Kendrick and Langner 1991). Abraham et al. (2000) reported that previously published data on permeability measurements under specified high-pressure differences might have underestimated the flow for low-pressure calculations by neglecting a correction factor for slip. Permeability measurements at high-pressure differences (e.g., 25 – 100 psi) have been found not to scale linearly to small

pressure differences (e.g., 5 – 15 Pa) symbolic of advective radon entry problems (Colle 1981; Abraham et al. 2000).

This paper reports the preliminary experimental findings of determining the dependence of the permeability coefficient on the applied pressure difference across a concrete sample that simulates radon entry conditions in residential construction. An experimental system that utilizes control technology, PC-data acquisition, and state-of-the-art instrumentation is used to measure the permeability of a standard-mixture concrete sample at pressure differences between 5 and 15 Pa (7.252×10^{-4} – 2.176×10^{-3} psi).

EXPERIMENT

Concrete Sample

The concrete mix tested in this study was similar to that used by Abraham et al. (2000). The concrete mixture simulated a standard Wisconsin poured concrete basement foundation mix (Hool 1918; USBR 1938). The concrete was cast with a water-to-cement ratio of 0.5 and a cement-to-sand-pea gravel ratio of 1:2:4. A cylindrical aluminum holder was used for casting and to hold the concrete sample for testing. The concrete sample measured 4.2” in thickness and 3.5” in diameter with a porosity of 9.8% (Abraham 1999). Figure 1 is a photo of the concrete sample used in our measurements.

Permeability Apparatus

The permeability apparatus is shown in Figs. 2 and 3. The system consisted of high and low pressure chambers, the concrete sample, two identical mini proportional flow control valves (orifice size = 0.032”), highly sensitive and accurate instrumentation (pressure transducers, thermistors, and relative humidity sensors), as well as a high-speed PC-data acquisition and control system (PC-DACS). The visual programming language, HP VEE 5.0 was utilized to monitor conditions and electronically control the operation of the *needle* control valves via the PC-DACS. Details of the automated process are described by Abraham et al. (2000), and are not repeated here for brevity.

Permeability Coefficient

The permeability coefficient, K is the proportionality constant in Darcy’s law that relates the fluid flux through a porous material (e.g., intact concrete) to the pressure gradient. The value of K dictates the indoor radon entry rate by the advection transport mechanism. Darcy’s law as applied to our experimental setup is expressed as:

$$Q = - \frac{K A \Delta p}{\mu L} \quad (1)$$

where,

- Q = volumetric flow rate of air
- K = permeability coefficient
- A = cross-sectional area of the concrete sample
- Δp = applied pressure difference across the concrete

- μ = viscosity of air
- L = thickness of concrete sample.

The volumetric air flow rate is calculated from the ideal gas law and the molecular volume of air as described by Maas and Renken (1997). Complete details of the experimental setup and procedures can be found in Ferguson (2001).

RESULTS

Figure 4 displays the experimental data generated by this study. More specifically, the measured air permeability coefficients for the concrete sample tested at the prescribed pressure differences of 5, 10, 15 Pa as well as 1 psi (6,895 Pa) are reported. As shown, there exists a definitive increase in the value of K as the applied pressure difference is decreased. Table 1 lists the average values of K at the pressure differences tested. A 330% increase in the average value of K is realized when the pressure difference is decreased from 15 Pa to 5 Pa, respectively. Moreover, almost a 13,000% increase in K is documented for a comparison between the 1 psi (6,895 Pa) and 5 Pa measurements. It should be noted that these test runs at each prescribed pressure difference are dependent on the barometric pressure as well as the temperature and relative humidity levels within the test chambers during experimentation. The experimental uncertainty of the measured permeability coefficient is estimated to be approximately $\pm 5\%$ (Abraham et al. 2000).

The experimental results show that as the applied pressure difference decreases, the concrete realizes a significant change in the value of K . Past indoor radon entry rates due to advection have been calculated from permeability data based on measurements at much higher pressure differences (e.g., 100 psi). Thus, radon entry rates by advection through intact concrete should be greater if the low-pressure values (5 – 15 Pa) of K are employed. For example, we can use the simple model suggested by Nazaroff and Nero (1988) to estimate indoor radon concentration due to a typical residential pressure difference between the soil and the basement environment.

$$I = \left(\frac{S_v + I_o \lambda_v}{\lambda_v + d} \right) \quad (2)$$

where,

- I = indoor air radon concentration
- S_v = radon entry rate per unit volume
- I_o = outdoor air radon concentration ~ 0.4 pCi/L (Sextro 1988)
- λ_v = ventilation rate
- d = decay constant for radon = 0.0076/hr.

The radon gas entry rate per unit volume for a 5 Pa pressure difference across the concrete slab can be estimated by Darcy's law (Eqn. 1), where:

$$K_{avg.} = 10^{-16} \text{ m}^2 \text{ (permeability coefficient based on 1 psi data)}$$

- A = 140 m² (representative basement wall surface area)
- Δp = 5 Pa (representative pressure difference across a basement slab)
- μ = 1.846 x 10⁻⁵ kg/m-sec (viscosity of air at room temperature)
- L = 0.10 m ~ 4" (typical thickness of concrete basement slab).

Using these parameters, the volumetric flow rate due to the permeability of the concrete is $Q = 3.79 \times 10^{-8} \text{ m}^3/\text{s} = 0.136 \text{ L/hour}$. If we use an average radon concentration in the soil surrounding the residential structure value of 2,700 pCi/L (Nagda 1994), a radon entry rate of 230 pCi/hour is realized. Next, if we use a typical house dilution volume of $10^3 \text{ m}^3 = 10^6 \text{ L}$, the entry rate per unit volume is $S_v = 2.31 \times 10^{-4} \text{ pCi/L-hour}$. With a negligible ventilation rate ($\lambda_v = 0$), the indoor equilibrium radon concentration level due to advective entry through an intact concrete slab is $I = 0.049 \text{ pCi/L}$. This appears to be a negligible contribution to the indoor radon gas level.

However, if we use the permeability data from this study with the same parameters, the results are much different. Our average permeability value measured at the 5 Pa pressure difference is $K = 1.39 \times 10^{-14} \text{ m}^2$. This value of K with identical conditions for advective radon entry and negligible ventilation produces an indoor equilibrium radon concentration of $I = 6.74 \text{ pCi/L}$, instead of 0.049 pCi/L.

If a ventilation rate of 0.5 ACH is used, the indoor radon concentration expected, due to the permeability of concrete alone, goes from 0.40 pCi/L (K based on 1 psi data) to 0.50 pCi/L (K based on 5 Pa data). A 25% increase in indoor radon level is realized. In radon-resistant new construction, a reduction of 0.1 pCi/L in many new homes would be significant if it were easily achieved. Although many factors can influence radon levels by larger amounts, here is one factor that can be expected to influence radon in all houses by more than heretofore expected, and may be subject to control in new construction.

CONCLUSIONS AND RECOMMENDATIONS

Preliminary experimental data is presented on the air permeability coefficient of intact concrete and its dependence on low-applied pressure differences of 5 – 15 Pa. It was found that there exists a significant difference in the permeability coefficient when the pressure differential across the concrete approaches actual residential construction conditions. This significant increase in the permeability is attributed to the *slip effect* and is highlighted when applied to the estimation of indoor radon entry by advection. It is recommended that further tests be conducted to fully characterize this *slip effect* and its dependence on concrete composition, age, and relative humidity level.

ACKNOWLEDGMENTS

The authors would like to thank Dr. Conrad V. Weiffenbach, Wisconsin Department of Health and Family Services for his input and the US EPA State Indoor Radon Grants Program for their sponsorship. Special thanks to Mr. George T. Abraham for his ideas and fabrication of the control loop system.

REFERENCES

Abraham, G. T. Experimental setup of a low pressure concrete sample permeability apparatus. Milwaukee, WI: University of Wisconsin-Milwaukee; December 1999 (Senior Design Project).

Abraham, G. T.; Daoud, W. Z.; Renken, K. J. Experimental measurements on the permeability coefficient of a concrete sample under low pressure differences. In: The 2000 International Radon Symposium. 12.1 – 12.12 Milwaukee, WI: AARST; 2000.

Colle, R; Rubin, R. J.; Knab, L. I.; Hutchinson, J. M. R. Radon transport through and exhalation from building materials: a review and assessment. National Bureau of Standards, Technical Note 1139. Washington, DC; 1981.

Ferguson, L. A. Further investigation on permeability testing of concrete under low pressure gradients. Milwaukee, WI: University of Wisconsin-Milwaukee; May 2001 (Independent Study Project).

Hool, G. A. Concrete Engineer's Handbook. New York: McGraw-Hill; 1918.

Kendrick, D. T.; Langner, G. Direct measurement of the dependence of radon flux through structure boundaries on differential pressure. In: The 1991 International Symposium on Radon and Radon Reduction Technology. Vol. 3: US EPA; 1991.

Lambert, T. L.; Renken, K. J. Experiments on industrial by-product utilization as a concrete admixture to reduce radon gas transport properties. In: The 1999 International Radon Symposium. 13.0-13.10 Las Vegas, NV: AARST; 1999.

Maas, J. J.; Renken, K. J. Laboratory assessment of cementitious coatings as a barrier to radon gas entry. In: The 1997 International Radon Symposium. 1.1 - 1.13 Cincinnati, OH: AARST; 1997.

Nagda, N. L. Radon: prevalence, measurements, health risks and control. ASTM Manual Series, Philadelphia, PA: ASTM; 1994.

Nazaroff, W. W.; Nero, A. V. Radon and its decay products in indoor air. New York: John Wiley & Son; 1988.

Nielson, K. K.; Rogers, V. C. Radon entry into dwellings through concrete floors. In: The 1991 International Symposium on Radon and Radon Reduction Technology. Vol. 3: US EPA; 1991.

Renken, K. J.; Rosenberg, T. Laboratory measurements of the transport of radon gas through concrete samples. Health Physics. 68:800-808; June 1995.

Rogers, V. C.; Nielson, K. K. Data and models for radon transport through concrete. In: The 1992 International Symposium on Radon and Radon Reduction Technology. Vol. 3: US EPA; 1992.

Rogers, V. C.; Nielson, K. K.; Lehto, M. A.; Holt, R. B. Radon generation and transport through concrete foundations. EPA-600/R-94-175. US EPA, Research Triangle Park, NC: US EPA; September 1994.

Sanjuan, M. A.; Munoz-Martialay, R. Influence of the age on air permeability of concrete. *Journal of Materials Science*. 30:5657-5662; 1995.

Sanjuan, M. A.; Munoz-Martialay, R. Influence of the water/cement ratio on the air permeability of concrete. *Journal of Materials Science*. 31:2820-2832; 1996.

Sanjuan, M. A.; Munoz-Martialay, R. Variability of the concrete air permeability coefficient with time. *Building and Environment*. 32(1): 51-55; 1997.

Scott, A. Measurement of the surface permeability of basement concretes. EPA-600/R-93-169. US EPA, Research Triangle Park, NC: US EPA; September 1993.

Sextro, R. Radon in dwellings. In: *Radon and the Environment*. Park Ridge, New Jersey: Noyes Publications; 78; 1988.

Snoddy, R. Laboratory assessment of the permeability and diffusion characteristics of Florida concretes, phase I, methods development and testing. EPA-600/R-94-053. US EPA, Research Triangle Park, NC: US EPA; April 1994.

United States Bureau of Reclamation (USBR). *Concrete manual: a manual for the control of concrete construction*. Denver, CO: USBR; 1938.

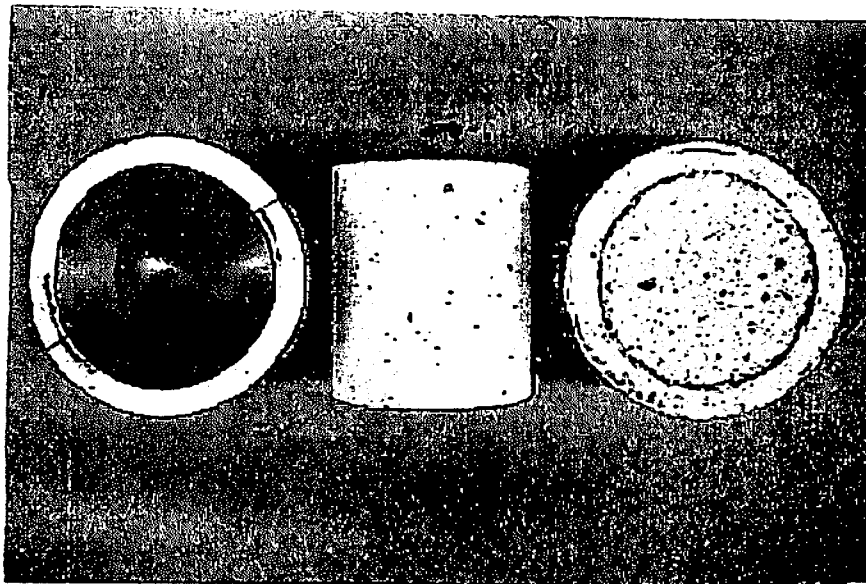

Fig. 1. Photo of concrete sample in aluminum holder

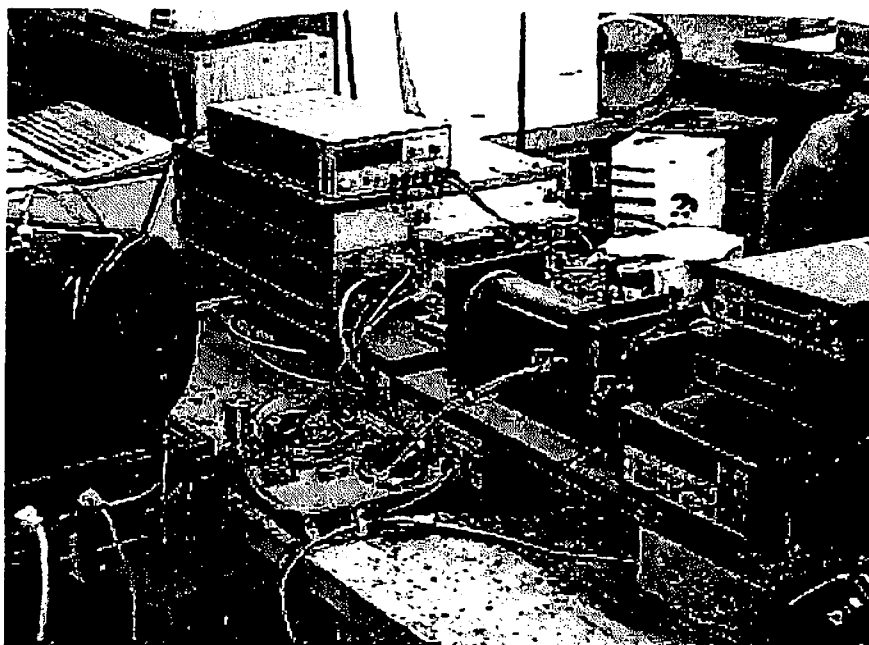

Fig. 2. Photo of experimental apparatus to measure the air permeability in concrete.

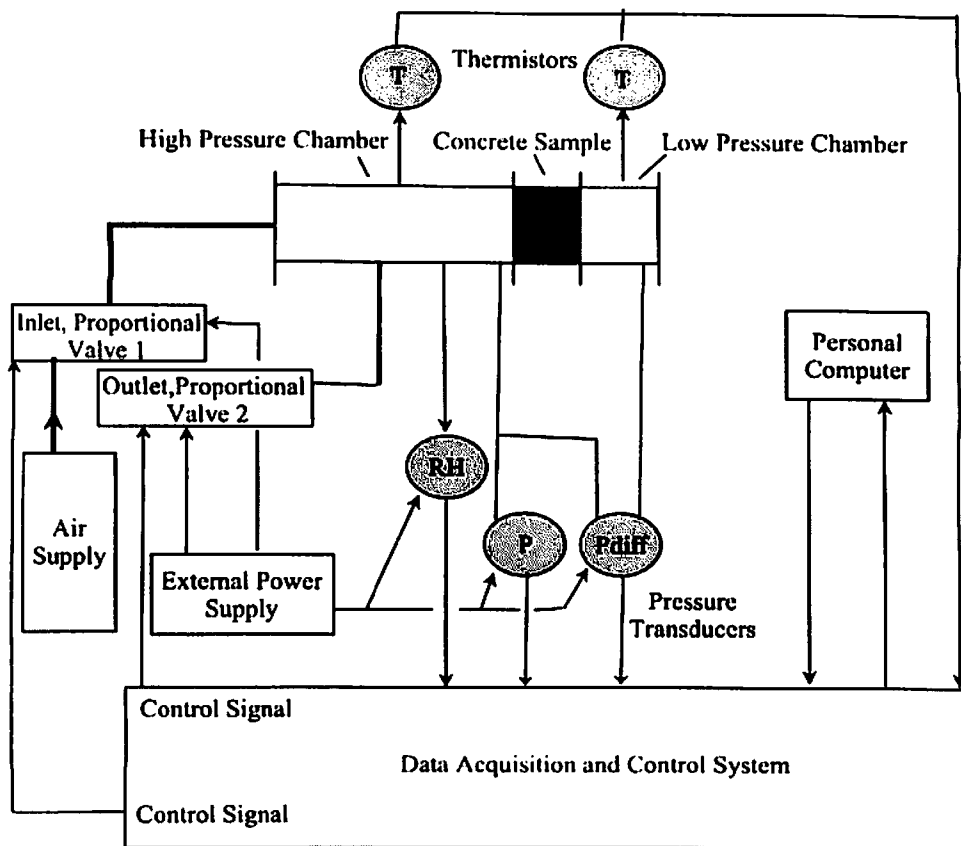

Fig. 3. Schematic diagram of system to measure the concrete sample's air permeability coefficient.

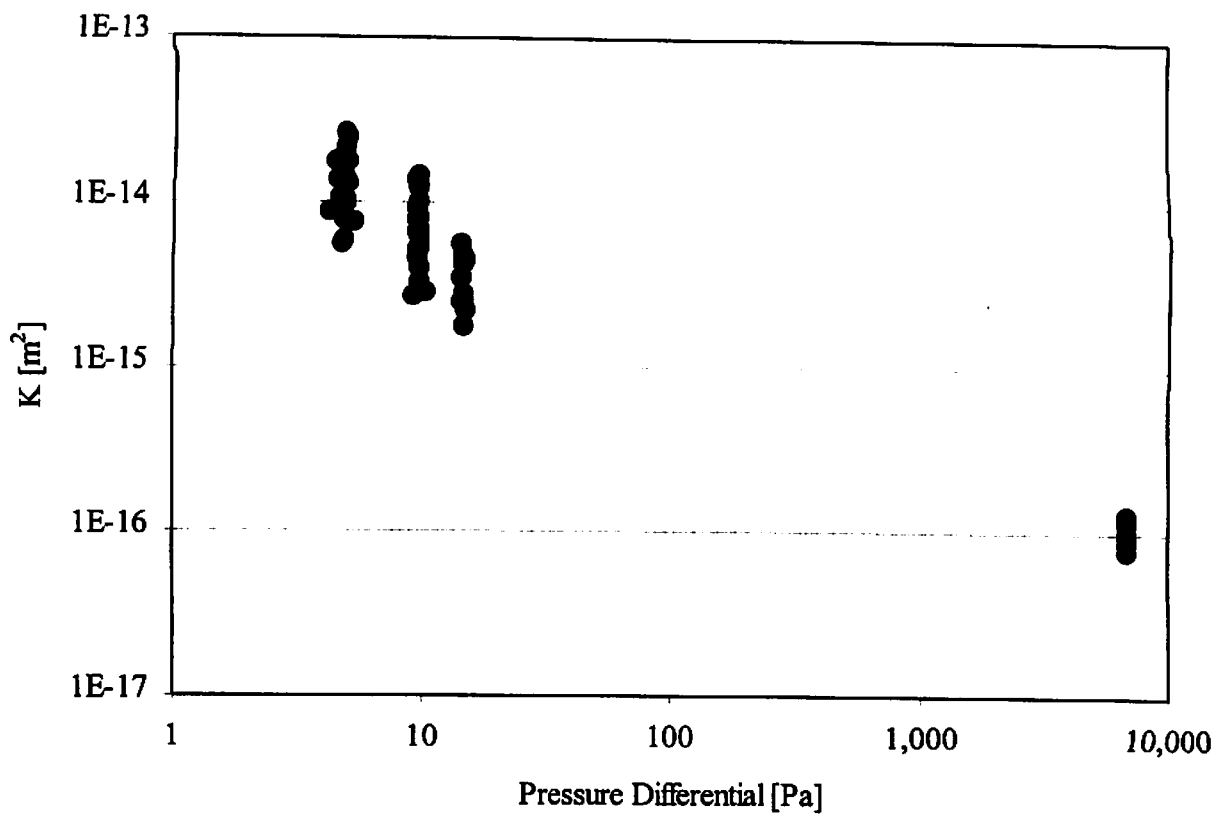

Fig. 4. Experimental results of air permeability coefficient versus applied pressure difference.

Table 1. Average values of measured air permeability at prescribed pressure differences.

Δp (Pa)	K (m^2)
5	1.39×10^{-14}
10	7.47×10^{-15}
15	3.25×10^{-15}
6895 (1 psi)	1.07×10^{-16}